

www.falc.eu  
e-mail: info@falc.eu

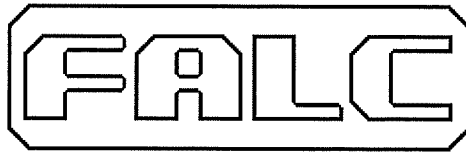

via Proventa n.41 – 48018 Faenza (Ra) - ITALY -  
☎ +39 0546 29050  
Fax +39 0546 663986

## Catalogo Ricambi / Spare Parts Book

Modello / Model:

# Trincia / Shredder VISION

Matricola / Serial number:

.....

LATO DESTRO  
RIGHT SIDE  
CÔTÉ DROITE  
RECHTS

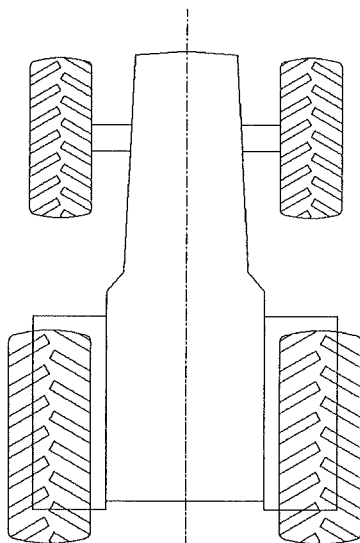

LATO SINISTRO  
LEFT SIDE  
CÔTÉ GAUCHE  
LINKS

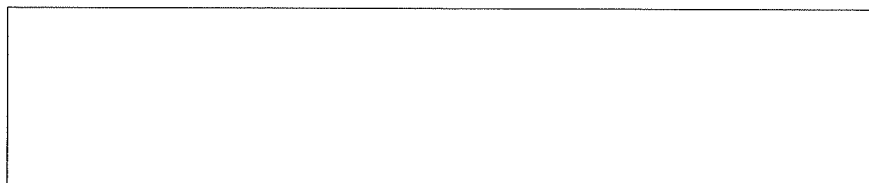

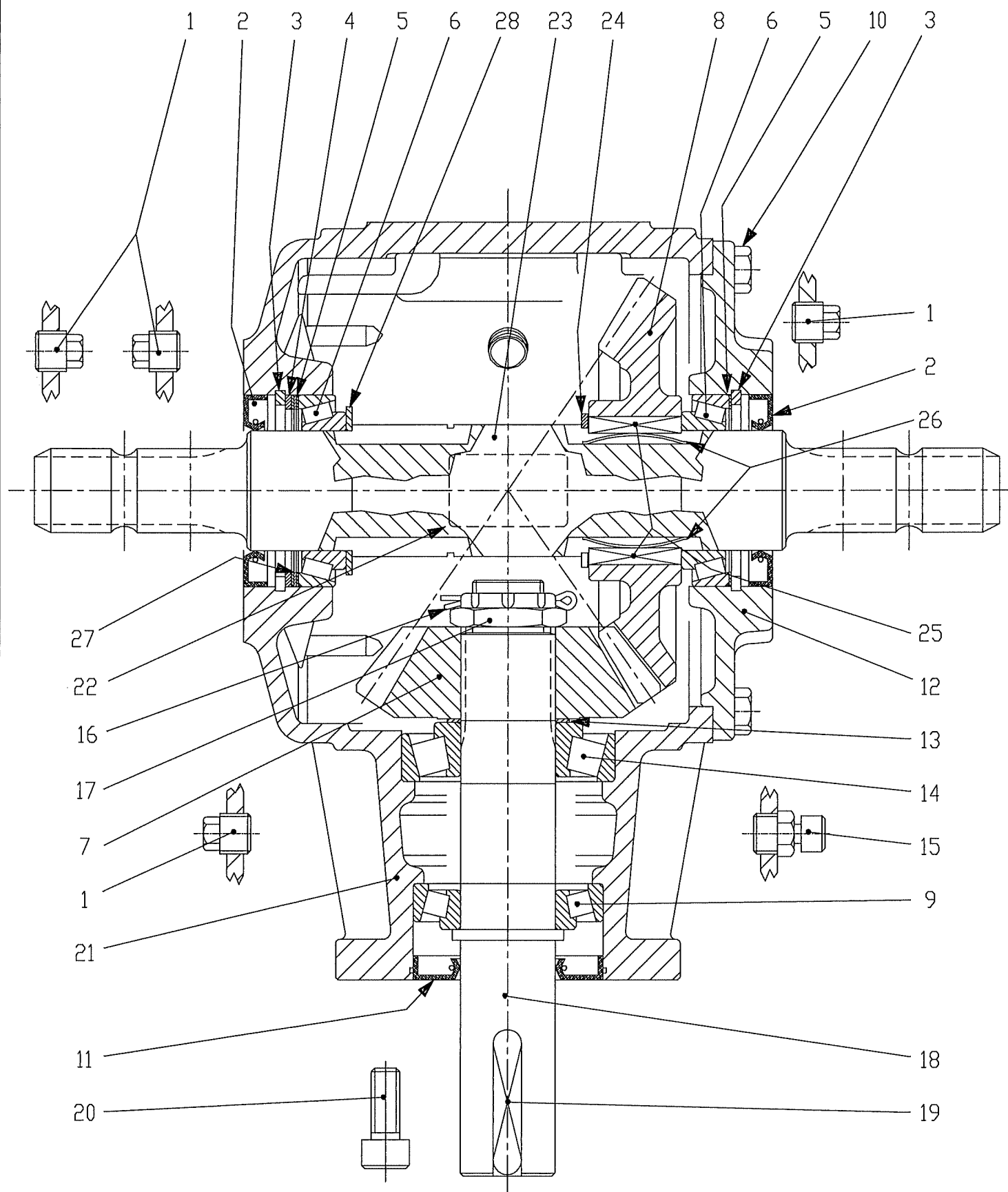

TL 290 Con Ruota Libera  
 PTO 1000 rpm – PTO Passante  
 Vision 2700–3200–3600–4000

TAV.851

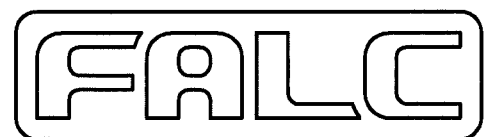

<b>Falc</b>	<b>Tavola Ricambi Parts Book</b>	<b>Vision 2700-3200-3600-4000</b>
pag.1	<b>n. 851 02/2014</b>	<b>Scatola TL 290 per PTO 1000 rpm Con Ruota Libera – PTO Passante Gearbox TL 290 for PTO 1000 rpm With Free Wheel – Through PTO</b>

<b>Pos. Fig.</b>	<b>Codice Item #</b>	<b>Descrizione Description</b>	
	90.2.135	Moltiplicatore PTO 1000 – Con Ruota Libera PTO Passante R=1:1,47 Comer cod. 9.290.629.00	Gearbox PTO 1000 – With Free Wheel Through PTO R=1:1,47 Comer item # 9.290.629.00
1	8.6.5.00006	Tappo conico con esagono esterno 3/8"	Conical plug with external hexagon 3/8"
2	07.0.009	Paraolio 50x80x10	Oil seal 50x80x10
3	05.1.017	Seeger per interni d 80 s=4 UNI 7438 serie pesante	Snap ring d 80 s=4 UNI 7438
4	0.267.7525.00	Spessore di registro 69,0x79,7x2,5	Shim 69,0x79,7x2,5
5	0.267.7500.00	Spessore di registro 69,0x79,9	Shim 69,0x79,9
6	06.1.063	Cuscinetto a rulli conici 32010	Taper roller bearing 32010
7	0.272.6001.00	Pignone conico z=19	Conical pinion z=19
8	0.290.6222.00 (ex 0.290.6217.00)	Corona conica z=29 – PTO 1000	Crown wheel z=29 – PTO 1000
9	06.1.041	Cuscinetto a rulli conici 30208	Taper roller bearing 30208
10	01.0.153	Vite TE M10 L=25 tf UNI 5739	Screw TE M10 L=25 tf UNI 5739
11	07.0.034	Paraolio 40x80x10	Oil seal 40x80x10
12	0.290.1367.00	Coperchio	Cap
13	0.244.7500.00	Spessore di registro 40,3x51,5	Shim 40,3x51,5
14	06.1.024	Cuscinetto a rulli conici 30308	Taper roller bearing 30308
15	8.6.7.00161	Tappo sfiato anticondensa 3/8	Anticondensate breather 3/8
16	05.3.018	Copiglia ø4 L=55 – UNI 1336	Split pin ø4 L=55 – UNI 1336
17	0.132.7106.00	Dado esagonale a intagli M30x1.5	Hexagonal nut M30x1.5
18	0.290.2000.00	Albero liscio	Smooth shaft
19	8.4.1.01834	Linguetta temprata	Tempered tongue
20	01.2.204	Vite TCEI M12 L=30 tf UNI 5931	Screw TCEI M12 L=30 tf UNI 5931
21	0.290.0308.00	Scatola	Gearbox
22	0.124.7101.00	Targhetta	Plate
23	0.290.3049.00	Albero calettato passante	Through splined shaft
24	05.0.027	Seeger per esterni d 55 s=3 UNI 7436	Snap ring d 55 s=3 UNI 7436
25	0.269.7119.00	Linguetta per ruota libera	Tongue for free wheel
26	0.267.7120.00	Molla a lamina per ruota libera	Spring for free wheel
27	0.267.7510.00	Spessore di registro 69.0x79.7x2.5	Shim 69.0x79.7x2.5
28	0.712.7525.00	Spessore di registro 70.3x50.3x2.5	Shim 70.3x50.3x2.5

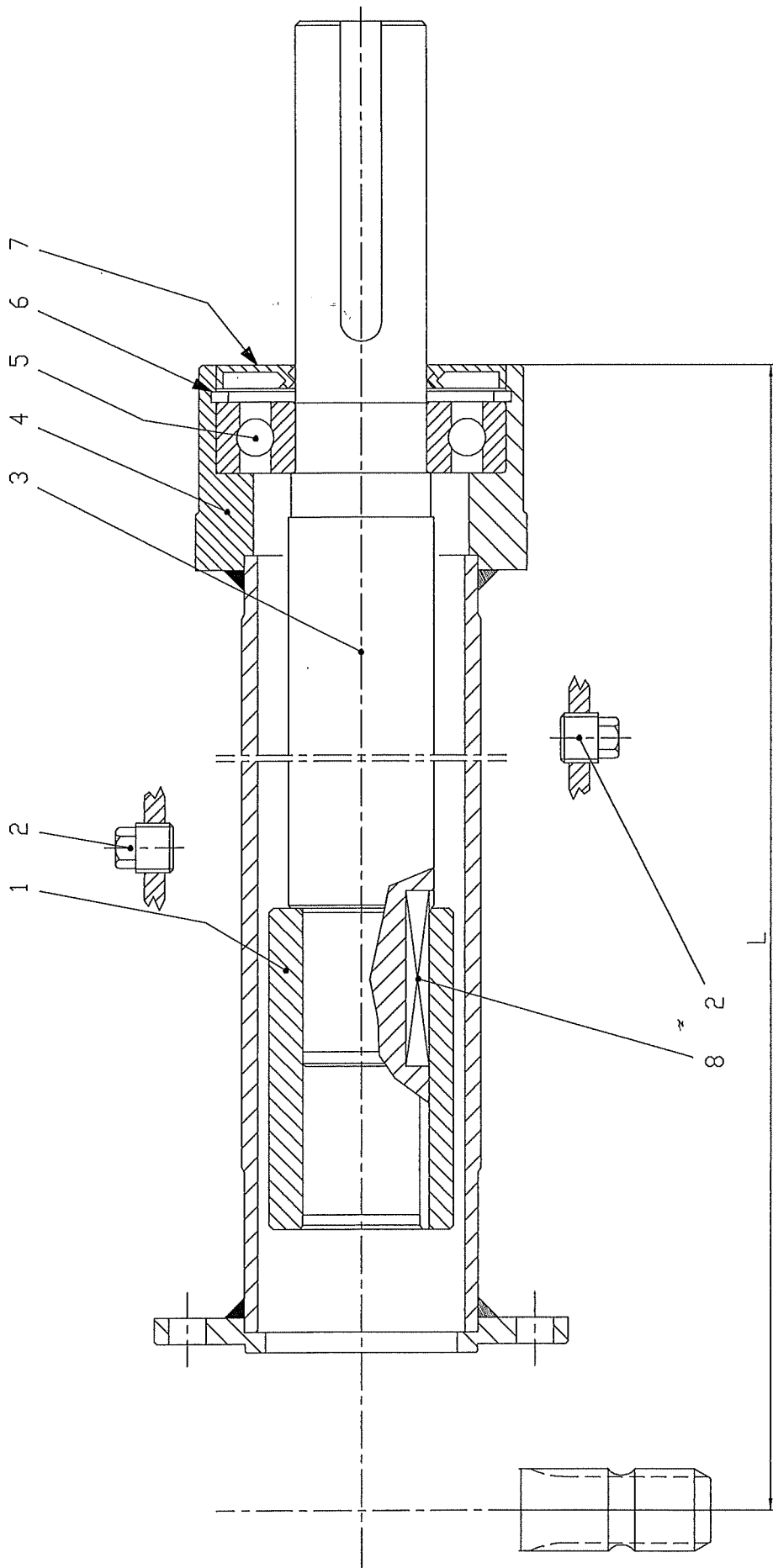

TAV. 768

**FRALC**

Prolunga TL 290 Senza Ruota Libera  
 Wind / Vision / Zenit / Unika / Vortex  
 Alce 3200 / Super Alce 2700-3200

<b>Falc</b>	<b>Tavola Ricambi Parts Book</b>	<b>Trincia con TL 290 Shredder with TL 290</b>
pag.1	<b>n. 768 05/2017</b>	<b>Prolunga TL 290 – Senza Ruota Libera Jackshaft TL 290 – Without Free Wheel</b>

<b>Pos. Fig.</b>	<b>Codice Item #</b>	<b>Descrizione Description</b>	
	90.3.040	Prolunga COMPLETA L=590 <b>Zenit SP 1800-2100 con TL290</b>	COMPLETE jackshaft L=590 <b>Zenit SP 1800-2100 with TL290</b>
	90.3.038	Prolunga COMPLETA L=600 cod. 9.290.501.00 <b>Super Sax con TL290</b>	COMPLETE jackshaft L=600 Item # 9.290.501.00 <b>Super Sax with TL290</b>
	90.3.041	Prolunga COMPLETA L=755 <b>Zenit Avant 2100 con TL290</b>	COMPLETE jackshaft L=755 <b>Zenit Avant 2100 with TL290</b>
	90.3.042	Prolunga COMPLETA L=785 <b>Zenit SP 2300 con TL290</b>	COMPLETE jackshaft L=785 <b>Zenit SP 2300 with TL290</b>
	90.3.043	Prolunga COMPLETA L=925 <b>Zenit SP 2500 / Zenit Avant 2300-2500 Unika SP 2300-2500 con TL290</b>	COMPLETE jackshaft L=925 <b>Zenit SP 2500 / Zenit Avant 2300-2500 Unika SP 2300-2500 with TL290</b>
	90.3.044	Prolunga COMPLETA L=1035 <b>Zenit SP 2700 / Zenit Avant 2700 Unika SP 2700 con TL290</b>	COMPLETE jackshaft L=1035 <b>Zenit SP 2700 / Zenit Avant 2700 Unika SP 2700 with TL290</b>
	90.3.039	Prolunga COMPLETA L=1115 <b>Vortex 2100 con TL290</b>	COMPLETE jackshaft L=1115 <b>Vortex 2100 with TL290</b>
	90.3.045	Prolunga COMPLETA L=1175 <b>Zenit SP 3000 / Zenit Avant 3000 Unika SP 3000 / Unika Fisso 2300 con TL290</b>	COMPLETE jackshaft L=1175 <b>Zenit SP 3000 / Zenit Avant 3000 Unika SP 3000 / Unika Fisso 2300 with TL290</b>
	90.3.046	Prolunga COMPLETA L=1330 <b>Unika Fisso 2500-2700 con TL290</b>	COMPLETE jackshaft L=1330 <b>Unika Fisso 2500-2700 with TL290</b>
	90.3.033	Prolunga COMPLETA L=1400 cod. 9.290.505.00 <b>Wind – Vision – Super Alce 2700</b>	COMPLETE jackshaft L=1400 Item # 9.290.505.00 <b>Wind – Vision – Super Alce 2700</b>
	90.3.034	Prolunga COMPLETA L=1670 cod. 9.290.508.00 <b>Wind – Vision – Alce – Super Alce 3200</b>	COMPLETE jackshaft L=1670 Item # 9.290.508.00 <b>Wind – Vision – Alce – Super Alce 3200</b>
	90.3.036	Prolunga COMPLETA L=1770 cod. 9.290.528.00 <b>Wind – Vision 3600</b>	COMPLETE jackshaft L=1770 Item # 9.290.528.00 <b>Wind – Vision 3600</b>
	90.3.037	Prolunga COMPLETA L=2070 cod. 9.290.529.00 <b>Wind – Vision 4000</b>	COMPLETE jackshaft L=2070 Item # 9.290.529.00 <b>Wind – Vision 4000</b>
1	0.290.7000.00	Boccola di collegamento	Connection bushing
2	8.6.5.00006	Tappo conico con esagono esterno 3/8	Conical plug with external hexagon 3/8
3		NON DISPONIBILE	NOT AVAILABLE
4		NON DISPONIBILE	NOT AVAILABLE
5	06.0.021	Cuscinetto a sfere 6309	Ball bearing 6309
6	05.1.011	Seeger per interni d 100 s=3 UNI 7437	Snap ring d 100 s=3 UNI 7437
7	07.0.071	Paraolio 45x100x8 con parapolvere	Dust lip 45x100x8
8	8.4.1.01834	Linguetta temprata A 12x8x60 UNI 6604	Tempered tongue A 12x8x60 UNI 6604

# FALC

## TAV.856

### TRINCIA VISION

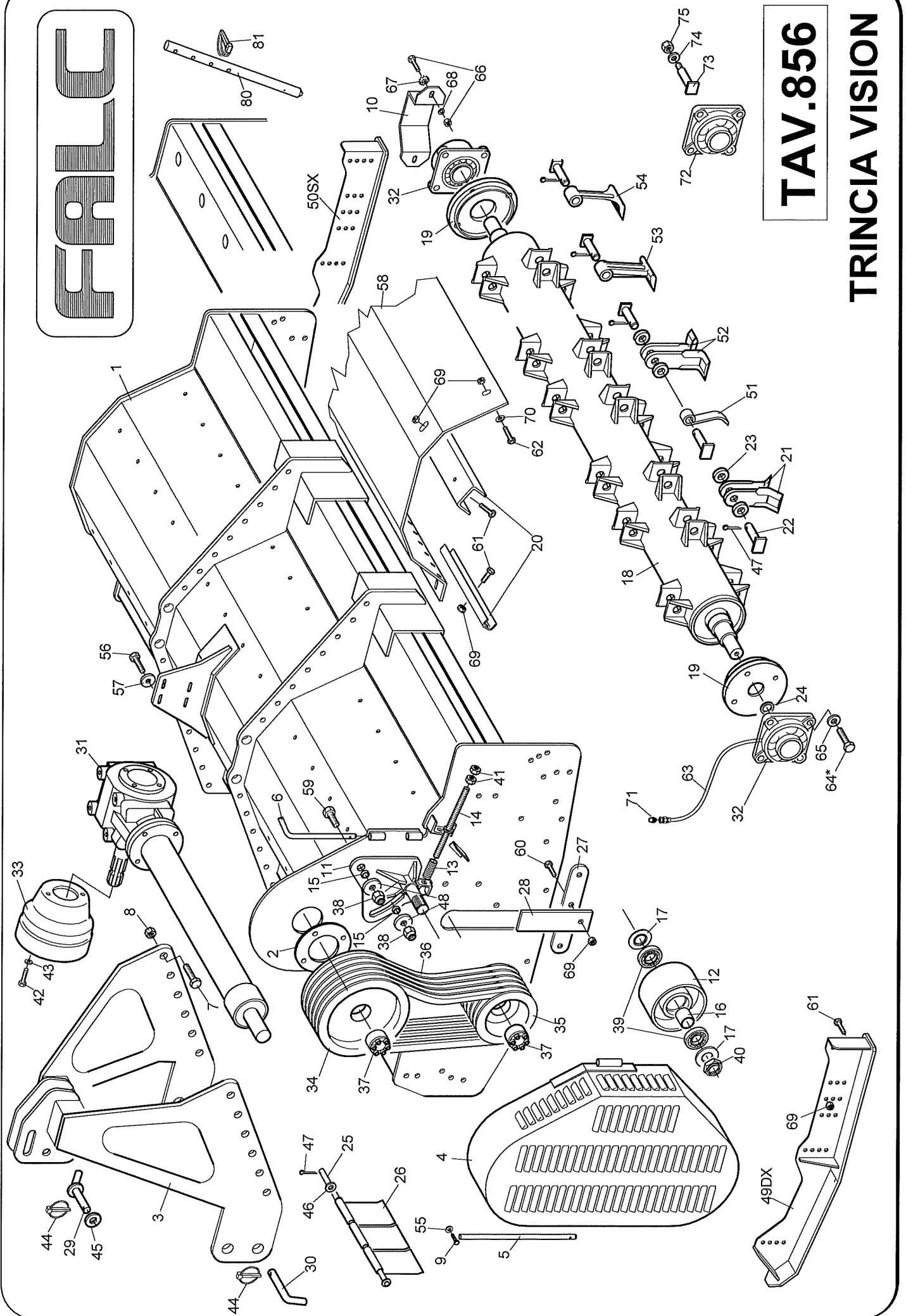

<b>Falc</b>	<b>Tavola Ricambi Parts Book</b>	<b>Trincia Vision Vision Shredder</b>
pag.1	<b>n. 856 12/2016</b>	<b>Telaio e rotore Frame and rotor</b>

<b>Pos. Fig.</b>	<b>Codice Item #</b>	<b>Descrizione Description</b>	
1	49.18.19	Telaio 2700	Frame 2700
	49.18.20	Telaio 3200	Frame 3200
	49.18.21	Telaio 3600	Frame 3600
	49.18.22	Telaio 4000	Frame 4000
2	49.18.54	Flangia prolunga TL290	Jackshaft flange TL 290
3	49.18.18	Attacco 3P	3 point linkage
4	83.00.02	Carter copricinghie	Belts cover
5	64.06.97	Perno cerniera carter copricinghie - ZINCATO	Hinge pin for cover – GALVANIZED
6	64.06.98	Perno fissaggio carter copricinghie - ZINCATO	Pin for belts cover fixing – GALVANIZED
7	01.1.206	Vite TE M16x1,5 l=50 tf UNI 5740	Screw TE M16x1,5 l=50 tf UNI 5740
8	02.5.004	Dado METALBLOC M16x1,5 h=14	Metalbloc nut M16x1,5 h=14
9	01.2.161	Vite TCEI M10 L=14 UNI 5931 ZINCATA	Screw TCEI M10 L=14 UNI 5931 GALVANIZED
10	41.04.05	Protezione cuscinetto UCF 212	Guarding for bearing UCF 212
11	64.05.32	Supporto tendicinghie dx	Rh belts tensioner support
12	64.05.02	Puleggia folle d 200 - De=200	Idler pulley d 200 – De=200
13	66.02.74	Molla - ZINCATA	Spring - GALVANIZED
14	74.00.53	Tirante molla tendicinghie - ZINCATO	Tie rod - GALVANIZED
15	66.02.89	Boccola guida tendicinghie L=13 - ZINCATA	Bush for belts tensioner L=13 - GALVANIZED
16	64.05.25	Distanziale tendicinghie L=58 - ZINCATO	Spacer for belts tensioner L=58 - GALVANIZED
17	64.05.24	Coperchio tendicinghie - ZINCATO	Belts tensioner cap - GALVANIZED
18	49.14.07	Rotore 2700 - per coltelli 01	Rotor 2700 – for blades 01
	49.14.08	Rotore 3200 - per coltelli 01	Rotor 3200 – for blades 01
	49.18.55	Rotore 3600 - per coltelli 01	Rotor 3600 – for blades 01
	49.18.56	Rotore 4000 - per coltelli 01	Rotor 4000 – for blades 01
19	41.04.65	Flangia supporto UCF 212	Flange for support UCF 212
20	41.04.52	Controcoltello liscio 2700	Smooth counterblade 2700
	41.04.51	Controcoltello liscio 3200	Smooth counterblade 3200
	49.11.12	Controcoltello liscio 3600	Smooth counterblade 3600
	64.00.27	Controcoltello liscio 3600-4000	Smooth counterblade 3600-4000
	64.00.26	Controcoltello liscio 4000	Smooth counterblade 4000
21	43.01.51	Coltello tipo 01	Blade type 01
22	42.03.35	Perno porta coltello	Blade pin
23	43.00.65	Distanziale coltelli tipo 01-05	Spacer for blades type 01-05
24	36.00.30	Rasamento di regolazione rotore s=1	Shim for rotor adjustment s=1
	5.709	Rasamento di regolazione rotore s=2	Shim for rotor adjustment s=2
25	83.00.88	Asta bandelle 2700	Rod for flaps 2700
	49.03.68	Asta bandelle 3200	Rod for flaps 3200
	92.00.88	Asta bandelle 3600	Rod for flaps 3600
	64.00.55	Asta bandelle 4000	Rod for flaps 4000
26	68.40.04	Protezione anteriore h=88	Front guarding h=88
27	68.30.18	Flangia piatto chiusura	Flange for closing plate
28	49.10.84	Piatto chiusura	Closing plate
29	42.07.43	Spina 3p superiore	Pin for top 3 point linkage
30	51.00.70	Spina 3p inferiore 2a cat.	Pin for bottom 3 point linkage cat. 2

<b>Falc</b>	<b>Tavola Ricambi Parts Book</b>	<b>Trincia Vision Vision Shredder</b>
pag.2	<b>n. 856 12/2016</b>	<b>Telaio e rotore Frame and rotor</b>

<b>Pos. Fig.</b>	<b>Codice Item #</b>	<b>Descrizione Description</b>
----------------------	--------------------------	------------------------------------

31	90.2.135	Scatola TL 290 - CON R.L. – PTO 1000 - PTO passante Prolunga L=1400 per 2700 Prolunga L=1670 per 3200 Prolunga L=1770 per 3600 Prolunga L=2070 per 4000	Gearbox TL 290 – WITH F.W. – PTO 1000 – through PTO Jackshaft L=1400 for 2700 Jackshaft L=1670 for 3200 Jackshaft L=1770 for 3600 Jackshaft L=2070 for 4000
32	06.4.005	Cuscinetto UCF 212	Bearing UCF 212
33	10.0.505	Protezione pto in plastica	Plastic pto guarding
34	08.2.035	Puleggia SPB 280/6	Pulley SPB 280/6
35	08.2.051	Puleggia SPB 200/6 2700-3200	Pulley SPB 200/6 2700-3200
	08.2.052	Puleggia SPB 236/6 3600-4000	Pulley SPB 236/6 3600-4000
36	08.1.020	Cinghia SPB 1850 2700-3200	Belt SPB 1850 2700-3200
	08.1.017	Cinghia SPB 1900 3600-4000	Belt SPB 1900 3600-4000
37	08.3.009	Calettatore VK 156	Keyer VK 156
38	02.4.005	Dado metalbloc M16 h=14	Metalbloc nut M16 h=14
39	06.0.043	Cuscinetto 6208 2RS1	Bearing 6208 2RS1
40	03.1.007	Ghiera autobloccante M40x1.5 h=16.5 GUP	Selflocking ring nut M40x1.5 h=16.5 GUP
41	02.0.005	Dado esagonale alto M16 h=16 UNI 5587	High hexagonal nut M16 h=16 UNI 5587
42	01.0.121	Vite TE M8 L=16 tf Zincata UNI 5739	Screw TE M8 L=16 tf Galvanized UNI 5739
43	04.1.226	Rosetta d=8 9x24x2 cat.C Zincata – UNI 6493	Washer d=8 9x24x2 cat.C Galvanized – UNI 6493
44	05.3.402	Spina a scatto d 10 L=58 art.104	Release pin d 10 L=58 art.104
45	04.1.235	Rosetta d 25 26x53x5 comune cat.C ZINCATA	Washer d 25 26x53x5 common cat.C GALVANIZED
46	04.1.005	Rondella M16 - 17x35x3	Washer M16 - 17x35x3
47	05.3.012	Copiglia d 5 L=40 UNI 1336	Split pin d 5 L=40 UNI 1336
48	04.1.227	Rosetta d 16 –18x48x4 UNI 6593 cat.C	Washer d 16 –18x48x4 UNI 6593 cat.C
49	68.30.55	Slitta regolabile dx	Rh adjustable skid
50	68.30.56	Slitta regolabile sx	Lh adjustable skid
51	43.08.53	Coltello di ventilazione	Ventilation blade
52	43.07.66	Coltello tipo 05	Blade type 05
53	43.02.51	Martello stampato	Printed hammer
54	68.00.71	Martello leggero	Light hammer
55	04.1.201	Rosetta d 10 - 10.5x21x2 UNI 6592 cat.A ZINCATA	Washer d 10 - 10.5x21x2 UNI 6592 cat.A GALVANIZED
56	01.0.204	Vite TE M12 L=30 tf - UNI 5739	Screw TE M12 L=30 tf - UNI 5739
57	04.1.232	Rosetta d=12 14x36x3 cat. C UNI 6593	Washer d=12 14x36x3 cat. C UNI 6593
58	49.18.05	Lamiera usura 2700 – in 2 pezzi L=1311	Wear & tear sheet 2700 – in 2 pieces L=1311
	49.18.06	Lamiera usura 3200 – in 2 pezzi L=1571	Wear & tear sheet 3200 – in 2 pieces L=1571
	49.18.79	Lamiera usura 3600 – in 2 pezzi L=1798	Wear & tear sheet 3600 – in 2 pieces L=1798
	49.18.80	Lamiera usura 4000 – in 2 pezzi L=1978	Wear & tear sheet 4000 – in 2 pieces L=1978
59	01.0.304	Vite TE M16 L=45 tf UNI 5739	Screw TE M16 L=45 tf UNI 5739
60	01.1.102	Vite TE M12x1,25 L=30 tf UNI 5738 ZINCATA	Screw TE M12x1,25 L=30 tf UNI 5738 GALVANIZED
61	01.1.104	Vite TE M12x1,25 L=35 tf UNI 5740	Screw TE M12x1,25 L=35 tf UNI 5740



<b>Falc</b>	<b>Tavola Ricambi Parts Book</b>	<b>Trincia Vision Vision Shredder</b>
pag.3	<b>n. 856 12/2016</b>	<b>Telaio e rotore Frame and rotor</b>

<b>Pos. Fig.</b>	<b>Codice Item #</b>	<b>Descrizione Description</b>	
62	01.1.102	Vite TE M12x1,25 L=30 tf UNI 5740	Screw TE M12x1,25 L=30 tf UNI 5740
63	64.05.65	Prolunga ingrassatore L=250	Greaser tube L=250
64*	01.1.253	Vite TE M18x1,5 L=55 tf UNI 5740	Screw TE M18x1,5 L=55 tf UNI 5740
65	04.0.007	Grower serie pesante d 18	Grower d 18
66	01.4.003	Vite TTQS M12 L=35 UNI 5732 con dado esagonale	Screw TTQS M12 L=35 UNI 5732 with hexagonal nut
67	04.1.202	Rosetta d 16 17x30x3 cat.A UNI 6592	Washer d 16 17x30x3 cat.A UNI 6592
68	04.0.004	Grower serie pesante d 12	Grower d 12
69	02.3.002	Dado autobloccante M12x1,25 h=14,8 UNI 7473	Selflocking nut M12x1,25 h=14,8 UNI 7473
70	04.1.003	Rondella M12 - 13x27x3	Washer M12 - 13x27x3
71	09.2.501	Ingrassatore dritto a spillo M6	Greaser M6
72	06.4.031	Cuscinetto UCF 212 in acciaio	Bearing steel UCF 212
73	42.03.43	Perno filettato porta martello	Threaded axle hammer holder
74	04.1.209	Rosetta d 18 19x34x3 UNI 6592 cat.A	Washer d 18 19x34x3 UNI 6592 cat.A
75	02.5.006	Dado metalbloc M18x1,5 h=17	Metalbloc nut M18x1,5 h=17
		<b>SOLO per macchine con barra posteriore forata</b>	<b>ONLY for machines equipped with rear drilled bar</b>
80	43.02.92	Dente rastrello L=660	Rake tine L=660
81	05.5.008	Spinotto d=6	Pin d=6

\* - Applicare loctite frenafili sulla vite

\* - Use locking paste on bolts

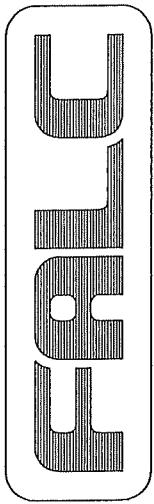

# RUOTA STERZANTE

TAV.495

- TRINCIA Alce 2500-2700
- TRINCIA Agila 2300-2500-2700
- TRINCIA Unika 2300-2500-2700
- TRINCIA Vision 2700-3200-3600-4000

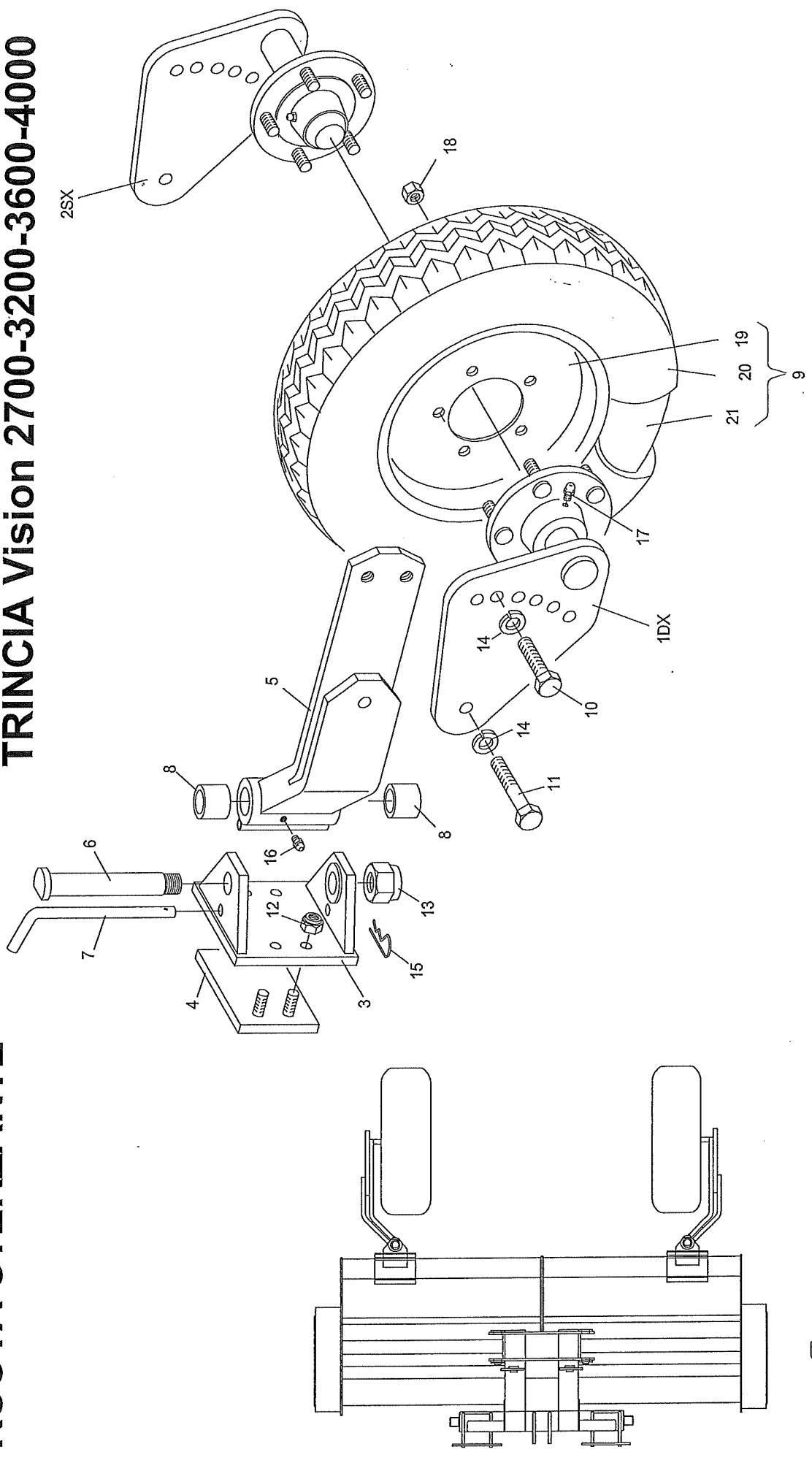

<b>Falc</b>	<b>Tavola Ricambi Parts Book</b>	<b>Alce 2500 – 2700 Agila 2300 – 2500 – 2700 Unika 2300 – 2500 – 2700 Vision 2700 – 3200 – 3600 – 4000</b>
pag.1	<b>n. 495 01/2014</b>	<b>Ruota Sterzante Steering Wheel</b>

<b>Pos. Fig.</b>	<b>Codice Item #</b>	<b>Descrizione Description</b>
----------------------	--------------------------	------------------------------------

	814.42	<b><u>Coppia ruote completa</u></b> Ruota 8.00-15 RI – disco 7Jx15 (5 fori) Per Alce 2500 – 2700 Agila 2300 – 2500 – 2700 // Unika 2300 – 2500 – 2700 Vision 2700 – 3200	<b><u>Complete pair of wheels</u></b> Wheel 8.00-15 RI – disc 7Jx15 (5 holes) For Alce 2500 – 2700 Agila 2300 – 2500 – 2700 // Unika 2300 – 2500 – 2700 Vision 2700 – 3200
	814.51	<b><u>Coppia ruote completa</u></b> Ruota 10.0/75-15.3 disco 9.00x15.3 (5 fori) Per Vision 3600 – 4000	<b><u>Complete pair of wheels</u></b> Wheel 10.0/75-15.3 disc 9.00x15.3 (5 holes) For Vision 3600 – 4000
1	49.03.03	Flangia dx con mozzo 5 colonnette	Rh flange with hub 5 stud bolts
2	49.03.04	Flangia sx con mozzo 5 colonnette	Lh flange with hub 5 stud bolts
3	43.00.72	Attacco snodo ruota sterzante	Articulation linkage for steering wheel
4	43.00.52	Piastra fissaggio attacco snodo ruota sterzante	Plate to fix articulation linkage of the steering wheel
5	49.09.15	Braccio ruota sterzante	Steering wheel arm
6	43.00.71	Perno snodo ruota sterzante	Pin for steering wheel
7	43.00.82	Spina bloccaggio ruota sterzante	Blocking pin for steering wheel
8	3.007	Boccola autolubrificante	Selflubricating bushing
9	49.09.10	<b><u>Alce 2500 - 2700</u></b> <b><u>Agila 2300 – 2500 – 2700 // Unika 2300</u></b> <b><u>– 2500 – 2700</u></b> <b><u>Vision 2700 – 3200</u></b> Ruota completa 8.00-15 RI – disco 7Jx15 (5 fori)	<b><u>Alce 2500 - 2700</u></b> <b><u>Agila 2300 – 2500 – 2700 // Unika 2300</u></b> <b><u>– 2500 – 2700</u></b> <b><u>Vision 2700 – 3200</u></b> Complete wheel 8.00-15 RI – disc 7Jx15 (5 holes)
	10.1.021	<b><u>Vision 3600 – 4000</u></b> Ruota completa 10.0/75-15.3 – disco 9.00x15.3 (5 fori)	<b><u>Vision 3600 – 4000</u></b> Complete wheel 10.0/75-15.3 – disc 9.00x15.3 (5 holes)
10	01.0.404	Vite TE M20 L=45 tf UNI 5739 zincata	Screw TE M20 L=45 tf UNI 5739 galvanized
11	01.0.406	Vite TE M20 L=70 pf UNI 5737 zincata	Screw TE M20 L=70 pf UNI 5737 galvanized
12	02.2.005	Dado Autobloccante M16 h=18 UNI 7473	Selflocking nut M16 h=18 UNI 7473
13	02.3.504	Dado Autobloccante M30x2 h=24,5 UNI 7474	Selflocking nut M30x2 h=24,5 UNI 7474
14	04.0.008	Grower serie pesante d 20	Grower d 20
15	05.3.202	Copiglia a molla d 4 art.114	Split pin d 4 art.114
16	09.2.504	Ingrassatore dritto a spillo M10	Greaser M10
17	09.2.501	Ingrassatore dritto a spillo M6	Greaser M6
18	10.2.266	Dado colonnetta M16x1,5 (GNK-FAD cod. 312F003)	Nut M16x1,5 (GNK-FAD item # 312F003)
19	10.1.301	Cerchio ruota 8.00-15 disco 7Jx15 (5 fori)	Wheel rim 8.00-15 disc 7Jx15 (5 holes)
20		<b>Per Ruota completa 8.00-15 RI – disco 7Jx15 (5 fori)</b>	<b>For complete Wheel 8.00-15 RI – disc 7Jx15 (5 holes)</b>
21	10.1.301	Disco 7Jx15 (5 fori)	Disc 7Jx15 (5 holes)
22	10.1.013	Gomma 8.00-15 RI	Tyre 8.00-15 RI
	10.1.104	Camera d'aria per ruota 8.00-15	Inner tube for wheel 8.00-15
20		<b>Per Ruota completa 10.0/75-15.3 – disco 9.00x15.3 (5 fori)</b>	<b>For complete Wheel 10.0/75-15.3 – disc 9.00x15.3 (5 holes)</b>
21	10.1.311	Disco 9.00x15.3 (5 fori)	Disc 9.00x15.3 (5 holes)
	10.1.024	Gomma 10.0/75-15.3	Tyre 10.0/75-15.3

Falc	Tavola Ricambi		Tavola Ricambi
	n. 506 3/2008 – KGN-FAD n. 507 3/2008 – KGN-FAD n. 508 3/2008 – KGN-FAD	Mozzo n.4 colonnette Mozzo n.5 colonnette Mozzo n.6 colonnette	n. 695 3/2008 - TVZ n. 696 3/2008 - TVZ n. 697 3/2008 - TVZ

Ricambi Assali – Semiassi senza Freno – Verificare marchio: GKN-FAD o TVZ ?

Umbreaker Axles and Stubs – Axles Spare Parts – Be careful: GKN-FAD or TVZ ?

Pieces de Rechange Essieux et Demi – Essieux sans Freins – Attention sVp: GKN-FAD ou TVZ ?

Ersatzteilliste für Achsen und Stummel Ohne Bremse – Achtung bitte: GKN-FAD oder TVZ ?

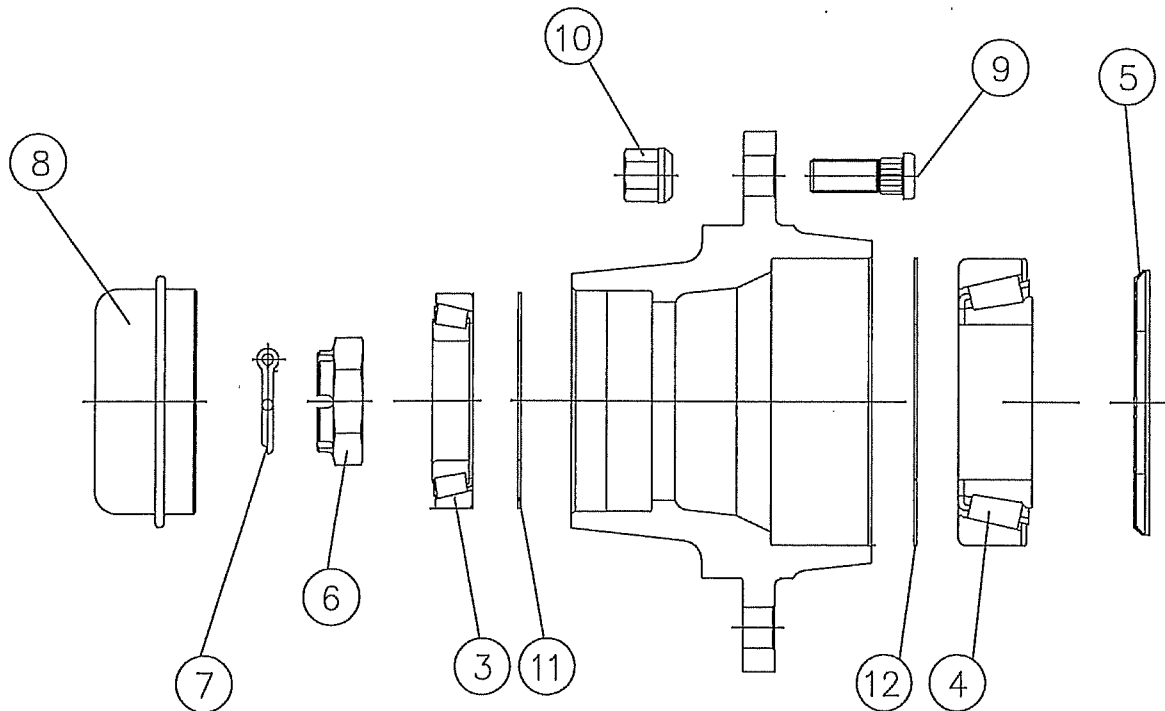

Pos.	Denominazione – Denimination – Designation - Benennung
3	Cuscinetto Esterno - Outer hub bearing - Roulement exterieur - Aussen lager
4	Cuscinetto interno - Inner hub bearing - Roulement interieur - Innen lager
5	Anello di tenuta - Retaining ring - Bague d'etancheite - Verdicht ungsring
6	Dado a intagli - Crown nut - Ecrou couronne - Kronenmutter
7	Copiglia - Split pin - Goupille - Splinte
8	Calotta - Hub cap - Calotte - Radkappe
9	Colonna - Wheel stud - Boulon - Bolzen
10	Dado colonna - Wheel nut - Ecrou - Bolzenmutter
11	Nilos – Solo per TVZ
12	Nilos – Solo per TVZ

<b>n. 506 3/2008</b>		<b>Mozzo n.4 colonnette Marchio GKN - FAD</b>	
<b>Pos.</b>	<b>Codice</b>	<b>Descrizione</b>	
3	06.1.056	Cuscinetto 30204	
4	06.1.001	Cuscinetto 30206	
5	10.2.272	Anello Tenuta Corteco 38x62x7	Gkn 324F009
6	10.2.270	Dado ad Intagli M18x1,5	Gkn 328F002
7	05.3.032	Copiglia A 3,5x25	Gkn 310F002
8	10.2.269	Calotta D. 47 Sigla Gkn-Fad	Gkn 307F043
9	10.2.263	Colonna M12x1,5 L=31 (tot. L=36)	Gkn 309F005
10	10.2.264 (ex 02.6.601)	Dado Colonna M12x1,5	Gkn 312F001
11	/	/	/
12	/	/	/

<b>n. 507 3/2008</b>		<b>Mozzo n.5 colonnette Marchio GKN - FAD</b>	
<b>Pos.</b>	<b>Codice</b>	<b>Descrizione</b>	
3	06.1.001	Cuscinetto 30206	
4	06.1.027	Cuscinetto 30209	
5	10.2.276	Anello Tenuta Corteco 53x85x8	Gkn 324F011
6	10.2.271	Dado ad Intagli M24x1,5	Gkn 328F010
7	05.3.011	Copiglia A 5x35	Gkn 310F004
8	10.2.268	Calotta D. 62 Sigla Gkn-Fad	Gkn 307F045
9	10.2.265	Colonna M16x1,5 L=45 (tot. L=50)	Gkn 309F008
10	10.2.266 (ex 02.6.602)	Dado Colonna M16x1,5	Gkn 312F003
11	/	/	/
12	/	/	/

<b>n. 508 3/2008</b>		<b>Mozzo n.6 colonnette Marchio GKN - FAD</b>	
<b>Pos.</b>	<b>Codice</b>	<b>Descrizione</b>	
3	06.1.001	Cuscinetto 30206	
4	06.1.027	Cuscinetto 30209	
5	10.2.273	Anello Tenuta Lamiera 45x85	Gkn 324F007
6	10.2.271	Dado ad Intagli M24x1,5	Gkn 328F010
7	05.3.011	Copiglia A 5x35	Gkn 310F004
8	10.2.268	Calotta D. 62 Sigla Gkn-Fad	Gkn 307F045
9	10.2.259	Colonna M18x1,5 L=49 (tot. L=54)	Gkn 309F004
10	10.2.260 (ex 02.6.603)	Dado Colonna M18x1,5	Gkn 312F010
11	/	/	/
12	/	/	/

	<b>n. 695 3/2008</b>	<b>Mozzo n.4 colonnette Marchio TVZ</b>		
<b>Pos.</b>	<b>Codice</b>	<b>Descrizione</b>		
3	<del>06.0.009</del> 06.0.008	Cuscinetto 6204 – 2RS1		
4	<del>06.0.011</del> 06.0.012	Cuscinetto 6206 – 2RS1		
5	10.2.410	Anello Tenuta Corteco 30x62x1,5		Tvz 5410621
6	02.2.006	Dado Autobloccante M18		Tvz 57918B1
7	/	/		/
8	10.2.401	Calotta D. 47 Sigla Tvz		Tvz 56104705
9	10.2.402	Colonna M12x1,5 L=35 (tot. L=40)		Tvz 57112B1
10	10.2.264 (ex 02.6.601)	Dado Colonna M12x1,5		Tvz 57312B1
11	/	/		/
12	/	/		/

	<b>n. 696 3/2008</b>	<b>Mozzo n.5 colonnette Marchio TVZ</b>		
<b>Pos.</b>	<b>Codice</b>	<b>Descrizione</b>		
3	06.1.001	Cuscinetto 30206		
4	06.1.027	Cuscinetto 30209		
5	10.2.403	Anello Tenuta Corteco 47x85x7		Tvz 5420851
6	10.2.404	Dado ad Intagli M27x1,5		Tvz 57527B1
7	10.2.405	Copiglia A 3x50		Tvz 58204
8	10.2.406	Calotta D. 62 Sigla Tvz		Tvz 56106210
9	10.2.265	Colonna M16x1,5 L=45 (tot. L=50)		Tvz 57116B1
10	10.2.266 (ex 02.6.602)	Dado Colonna M16x1,5		Tvz 57316B1
11	10.2.407	Nilos 33/62x0,5		Tvz 5510621
12	10.2.408	Nilos 49/85x0,5		Tvz 5510851

	<b>n. 697 3/2008</b>	<b>Mozzo n.6 colonnette Marchio TVZ</b>		
<b>Pos.</b>	<b>Codice</b>	<b>Descrizione</b>		
3	06.1.001	Cuscinetto 30206		
4	06.1.027	Cuscinetto 30209		
5	10.2.409	Anello Tenuta Corteco 45x85x2		Tvz 5410851
6	10.2.404	Dado ad Intagli M27x1,5		Tvz 57527B1
7	10.2.405	Copiglia A 3x50		Tvz 58204
8	10.2.406	Calotta D. 62 Sigla Tvz		Tvz 56106210
9	10.2.259	Colonna M18x1,5 L=49 (tot. L=54)		Tvz 57118B1
10	10.2.260 (ex 02.6.603)	Dado Colonna M18x1,5		Tvz 57318B4
11	10.2.407	Nilos 33/62x0,5		Tvz 5510621
12	10.2.408	Nilos 49/85x0,5		Tvz 5510851

DIS.01.1.203 VITE TE M16x1.5  
L=40 pf UNI 5738

DIS.41.09.83  
BRACCIO DX

DIS.01.1.166  
VITE TE M14x1.5  
L=40 pf UNI 5738

DIS.01.1.165 VITE TE M14x1.5  
L=50 pf UNI 5738

DIS.02.5.003 DADO  
METALBLOC M14x1.5 h=12

DIS.02.3.004 DADO  
AUTOBLOCCANTE M16x1.5 UNI 7473

DIS.02.5.003 DADO  
METALBLOC M14x1.5 h=12

RULLO  $\phi$ 273  
DIS.49.18.60 WIND-VISION 4000  
DIS.49.18.59 WIND-VISION 3600  
DIS.49.18.58 WIND-VISION 3200  
DIS.49.18.57 WIND-VISION 2700

RASCHIATORE RULLO  
DIS.49.18.76 WIND-VISION 4000  
DIS.49.18.75 WIND-VISION 3600  
DIS.49.18.74 WIND-VISION 3200  
DIS.49.18.73 WIND-VISION 2700

DIS.41.09.84 BRACCIO SX

DIS.09.2.501  
INGRASSATORE M6

DIS.06.4.004 CUSCINETTO UCF 210

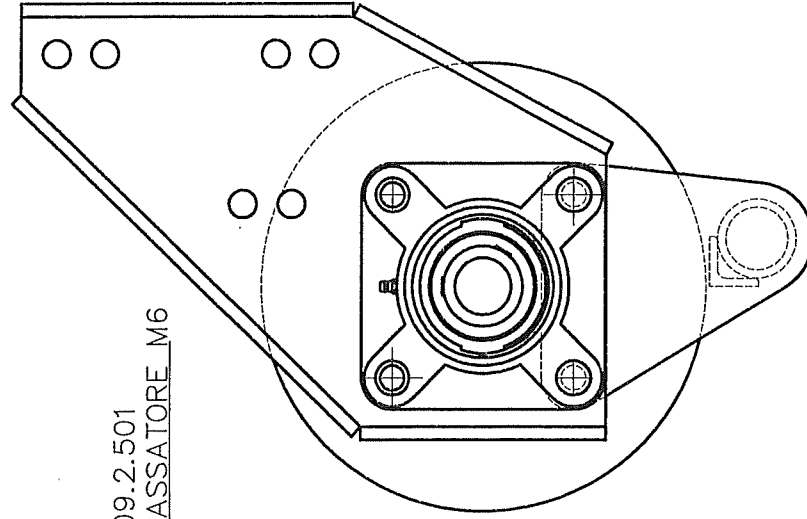

**TAV.860**

## TRINCIA WIND-VISION RULLO

**FALC**